



One Network
Enterprises™

One Network Logistics Control Tower

Carrier User Guide: Alerts and Milestones

Date: June 27, 2024

Version: 1.0

Table of Contents

- INTRODUCTION2
- ALERTS AND MILESTONES3
 - ALERTS.....3
 - Context..... 3
 - Process Flow..... 3
 - System Steps 4
 - MILESTONES.....11
 - Context..... 11
 - Process Flow..... 12
 - System Steps 12

Version Control

Version	Who	Notes
24-0627	NB	Updated standard formatting
24-0710	AH	Updated versioning and formatting

About One Network Enterprises

One Network Enterprises (ONE) is the leader in supply chain autonomous planning, control towers, and provider of the Digital Supply Chain Network™. It is the only solution that gives supply chain managers and executives end-to-end visibility and control with one data model and one truth, from raw material to last mile delivery. Powered by NEO, One Network’s machine learning and intelligent agent technology, it enables seamless planning and execution, across inbound supply, outbound order fulfillment, and logistics, matching demand with available supply in real-time. Lead your industry by providing the highest service levels and product quality at the lowest possible cost.

www.onenetwork.com

Introduction

The Bayer Crop Science Logistics control tower solution is a part of their inbound and outbound Supply Chain operations, Visibility & Data Program that aims at enabling a connected core of internal and external data for Global Operations in partnership with One Network. The solution will digitalize the segregated process of using different tools, software and provide end-to-end order and shipment visibility to all the stakeholders of the transactions.

The process would start from finding an eligible order, creating a parent point to point shipment against the order, getting the shipment booking with the LSPs/Suppliers freight forwarders and finally generating the shipment legs and storing the container details against the shipments (if applicable).

Shipment tracking information will be retrieved from multiple sources, including those of Suppliers and In-Country LSPs to ensure visibility across all shipment legs; with the existing FourKites integrations being linked through to ONE for a true single version of the truth across all operational phases. The events will be used to generate ETAs (Estimated Time of Arrival) (Estimated Time of Arrival) for deliveries based on the information provided by the source of data.

Additionally, ONE would also provide Alerting, Reporting, Milestones, Problem management and Dashboard capabilities that would give users actionable information and insights.

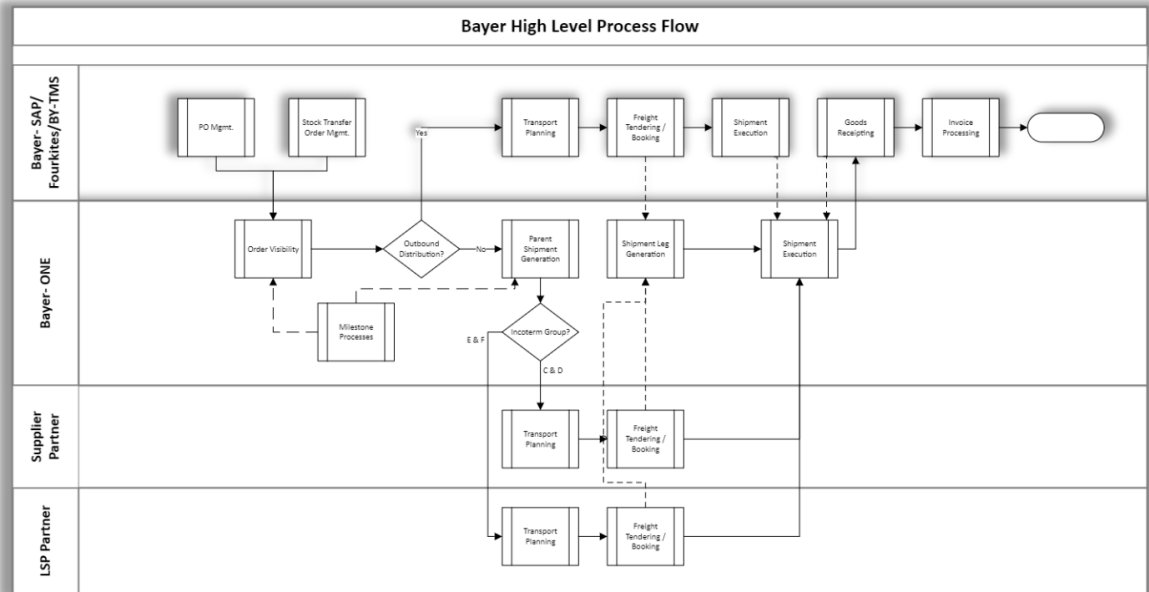

Alerts and Milestones

Alerts

Context

Activity Purpose	This activity enables Carrier users to set alerts and subscribe to alerts.
Activity Initiators	Carrier Users
Activity Prerequisites	Alerts need to be defined.
Activity Performer(s)	Transportation Manager
Other Parties Involved	
Additional Information	
Activity Outcome	User will get notified of the set alert by email or on UI

Process Flow

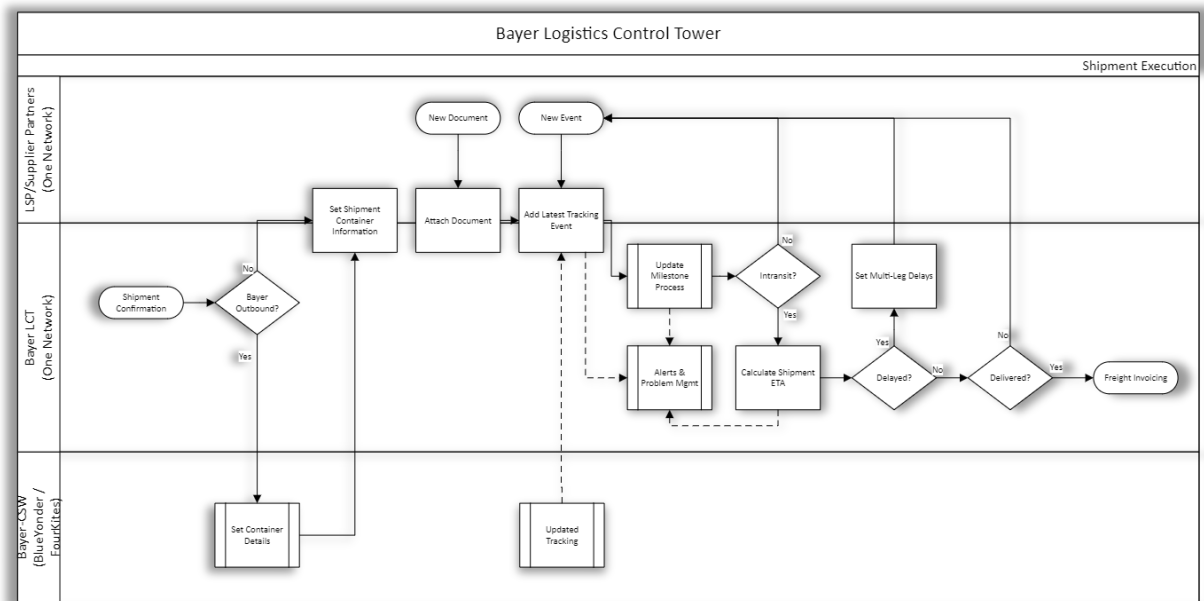

System Steps

The alerts subscription feature may be used by Bayer and its partners to set up alerts to receive email notifications or UI only notifications. For the phase one implementation, the key alert types that may be used are:

Shipment Alerts	Trigger	Recipient
Shipment Cancelled	This alert is triggered when a shipment is cancelled by the LSP, or the Bayer party involved in the transaction.	Bayer / LSP or Supplier
Shipment Event Alert	This alert is triggered when a specific event has been captured on a shipment transaction.	Bayer / LSP or Supplier
Shipment Line Added	This alert is triggered when a specific line is added to a shipment transaction.	Bayer / LSP or Supplier
Shipment Line Changed	This alert is triggered when an existing line is modified on a shipment transaction.	Bayer / LSP or Supplier
Shipment Line Deleted	This alert is triggered when an existing line is removed from a shipment transaction.	Bayer / LSP or Supplier
Shipment Update Alert	This alert is triggered when user specified fields have been modified on the shipment transaction.	Bayer / LSP or Supplier
Tender Plan not Determined Alert	This alert is triggered when the routing information is not available to generate a valid tender plan and require user intervention.	Bayer
Shipment Not Picked Up	This alert is triggered when a shipment picked up event has not been received.	Bayer / LSP or Supplier
Shipment Not Delivered	This alert is triggered when a shipment delivered event has not been received within the specified threshold.	Bayer / LSP or Supplier

Users can set Alerts notifying users of the upcoming Shipment milestones. The users can also get alerts based on tracking events like 'Confirmed,' 'Departed,' 'Delayed,' 'Reached' etc. As in the case of a delayed shipment, alerts are especially useful as they notify the user within configured time.

Any alerts related to Shipment transactions can be seen on the 'Alert Summary' report page.

NEO Dashboard with Alert Summary widget.

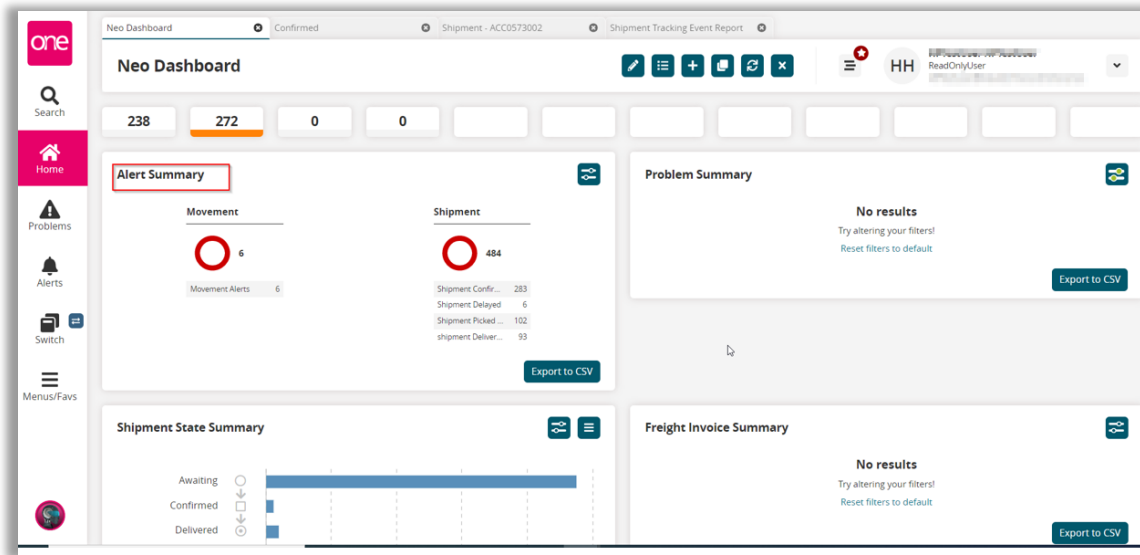

Subscribing to an Alert

1. Login to the One Network system.
2. Navigate to Menus/Favs -> Tools -> Alerts Subscriptions.

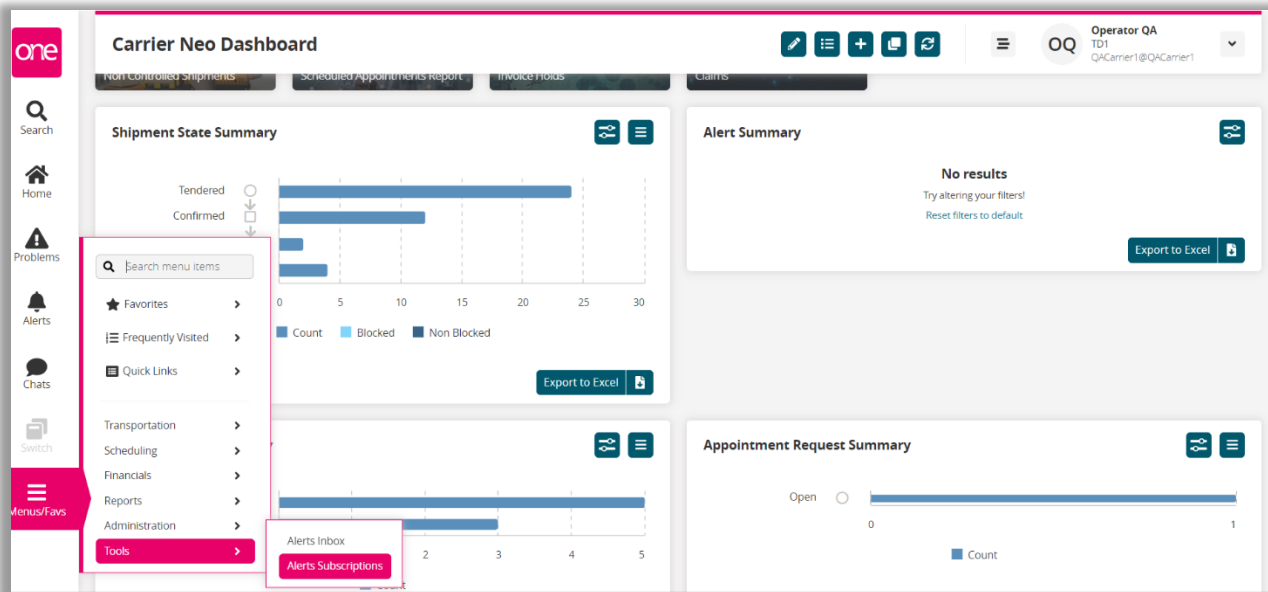

3. The **Alerts Subscriptions** screen displays a list of your current alert subscriptions.

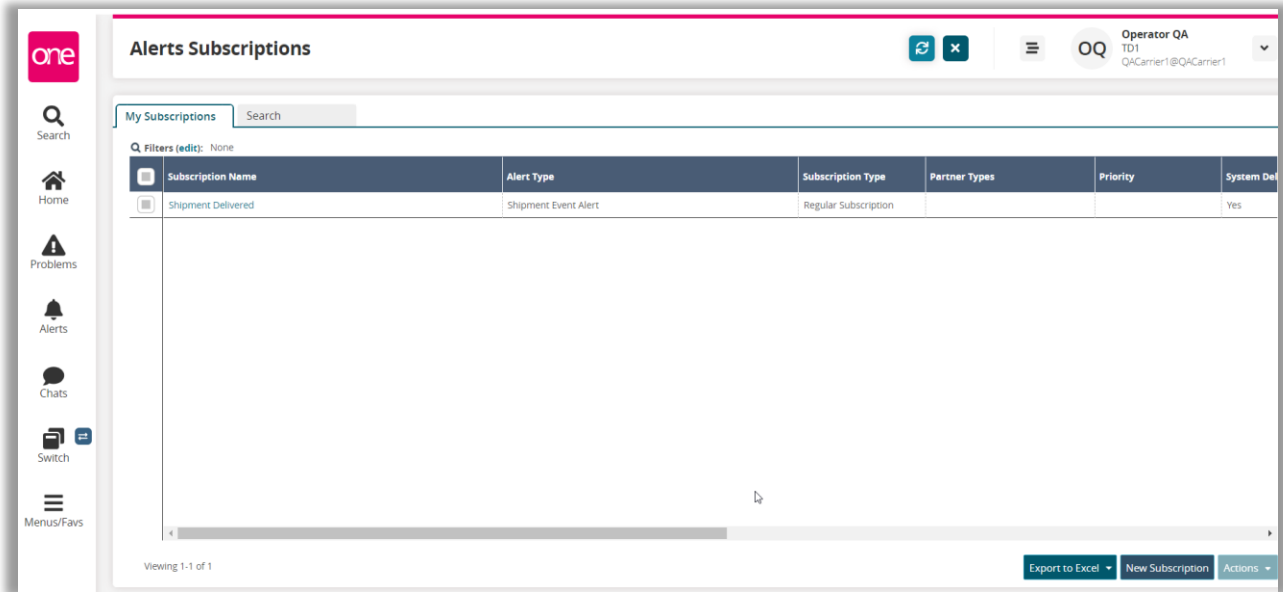

Note: To view or edit the details for an existing alert subscription, select the Alert Subscription name link under the Subscription Name column.

Creating New Alerts

1. To create a new alert subscription, click the New Subscription button.

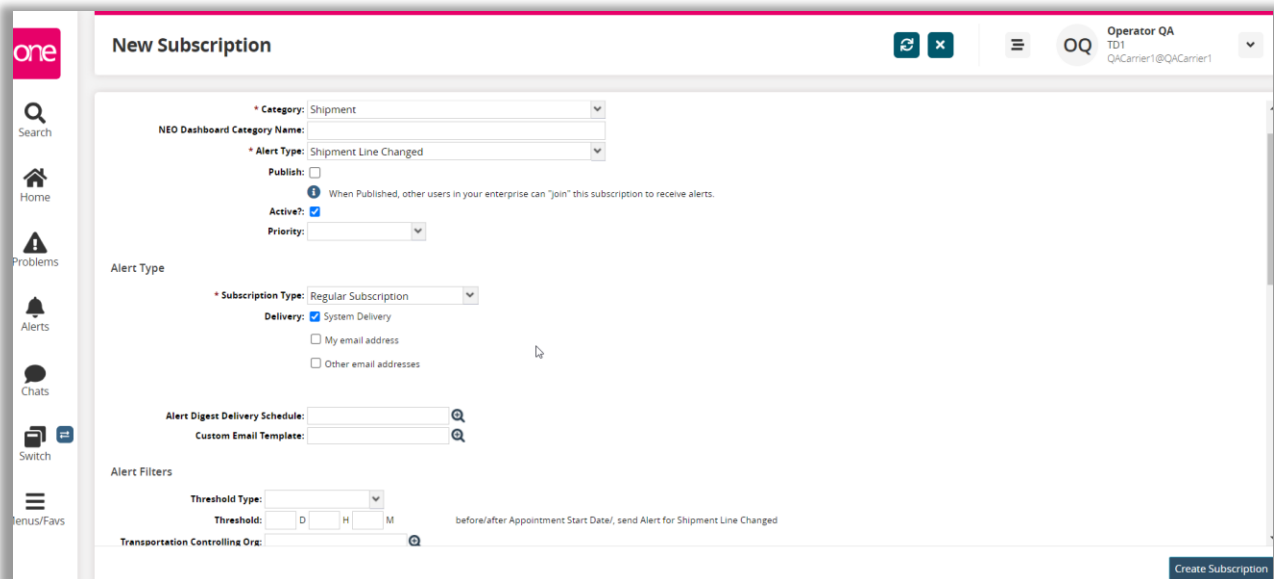

2. After clicking the New Subscription button, the New Subscription screen displays

This screen is divided into 3 sections:

- Alert Information
- Alert Type
- Alert Filters.

Note - the fields under the Alert Filters section will change depending on what type of alert is selected in the Alert Information section.

3. Enter and select information in the **Alert Information** section of the screen.

Note: Fields marked with an asterisk symbol (*) are required.

- **Subscription Name field** - enter a name for your alert.
- **Category field** - select one of the available categories from the Category drop-down list. If you want to subscribe to an alert based on the Movement or Shipment, select the Movement or Shipment category option.
- **Alert Type field** – once you select a **Category**, the list of corresponding Alert Types will become available. Select one of the available Alert Types from the Alert Type drop-down list. If you selected the Shipment Category, you could pick a specific alert such as **Shipment Not Picked**, or you can pick a general type of alert such as **Shipment Event Alert** which you would then specify the event for this alert in the **Alert Filters** section of the screen.

4. Next enter information in the **Alert Type** section of the screen.

This section allows you to send this alert to two different email addresses and to the system so you can see it within the application.

- For the **Email Delivery Option field**, select one of the selections from the drop-down list – **Alternate Email, Email, or None**

Note – If you select the Email option from the drop-down list, it will default to the email address specified for your username. The Alternate Email option from the drop-down list will allow you to enter any email address.

- For the **Secondary Delivery Option** field, select one of the selections from the drop-down list – Alternate Email, Email, or None

Note – If you select the Email option from the drop-down list, it will default to the email address specified for your username. The Alternate Email option from the drop-down list will allow you to enter any email address.

- Select the checkbox next to the System Delivery field if you want the alert to be seen in the application under your **Alert Inbox**

5. Enter information in the Alert Filters section of the screen.

- This section allows you to specify certain filter criteria that need to be met for this alert.
- For example, the Alert Filters section may include a **Ship from Site field** (depending on which alert type you selected). You could then specify a **Ship from Site** which means you would only get this alert for Shipments that contain this **Ship From Site**.

6. Once all the information has been entered on the New Subscription screen, click the Create Subscription button on the bottom right of the screen.

The screenshot displays the 'Shipment Line Changed' alert configuration interface. At the top, a green notification bar states 'Record was created successfully'. The main form is divided into sections: 'Alert Information' and 'Alert Type'. In the 'Alert Information' section, the 'Subscription Name' is 'Shipment Line Changed', the 'Category' is 'Shipment', and the 'Alert Type' is 'Shipment Line Changed'. There are checkboxes for 'Publish' and 'Active?' (checked), and a 'Priority' dropdown. The 'Alert Type' section includes a 'Subscription Type' dropdown (Regular Subscription) and 'Delivery' options: 'System Delivery' (checked), 'My email address', and 'Other email addresses'. At the bottom, there are fields for 'Alert Digest Delivery Schedule' and 'Custom Email Template'. A 'Save' button is located in the bottom right corner.

You will receive a message on the screen that the alert was successfully created.

7. Once an alert is triggered, you would get an email message to the email address you specified on the alert plus the alert will be sent to the system if you selected the **System Delivery checkbox**.

Viewing Alerts in Inbox

1. To view alerts sent to the system, navigate to **Menus/Favs -> Tools -> Alerts Inbox**.

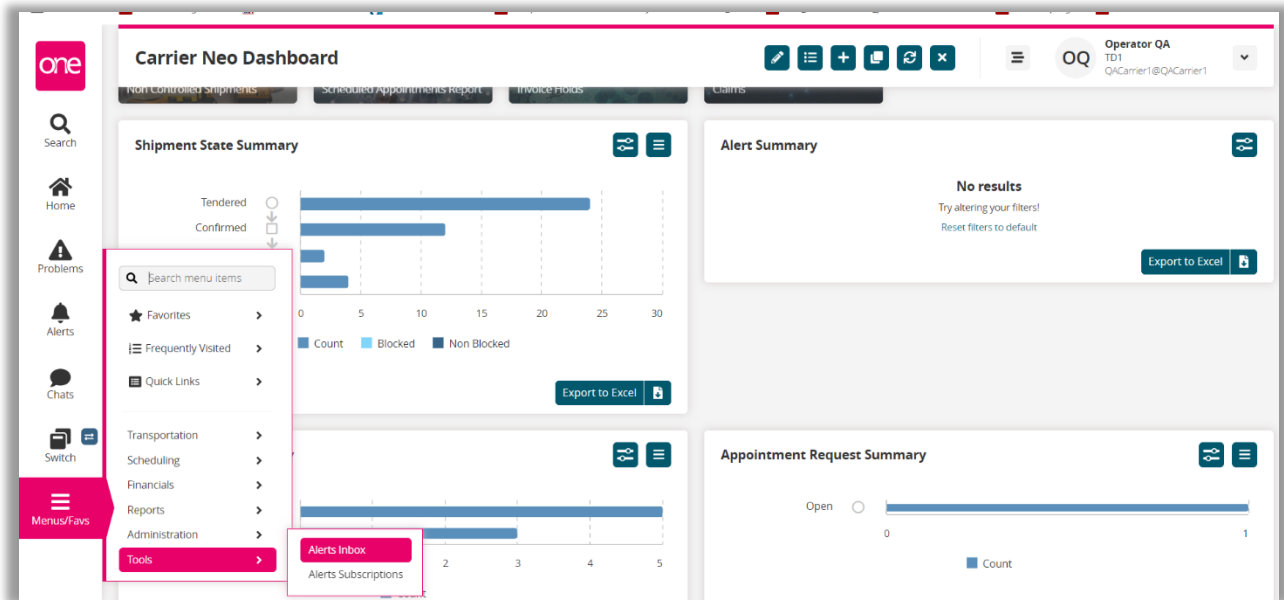

2. The Alerts Inbox screen shows a list of alerts sent to the system.

Note – this would be for the alerts where you selected the System Delivery checkbox.

The Alerts Inbox screen will list the date the alert was sent under the Date column and the name of your alert under the Subscription column.

You can filter and search for specific alerts by selecting the “Filters (edit)” link and then entering filter information and then pressing the Search link.

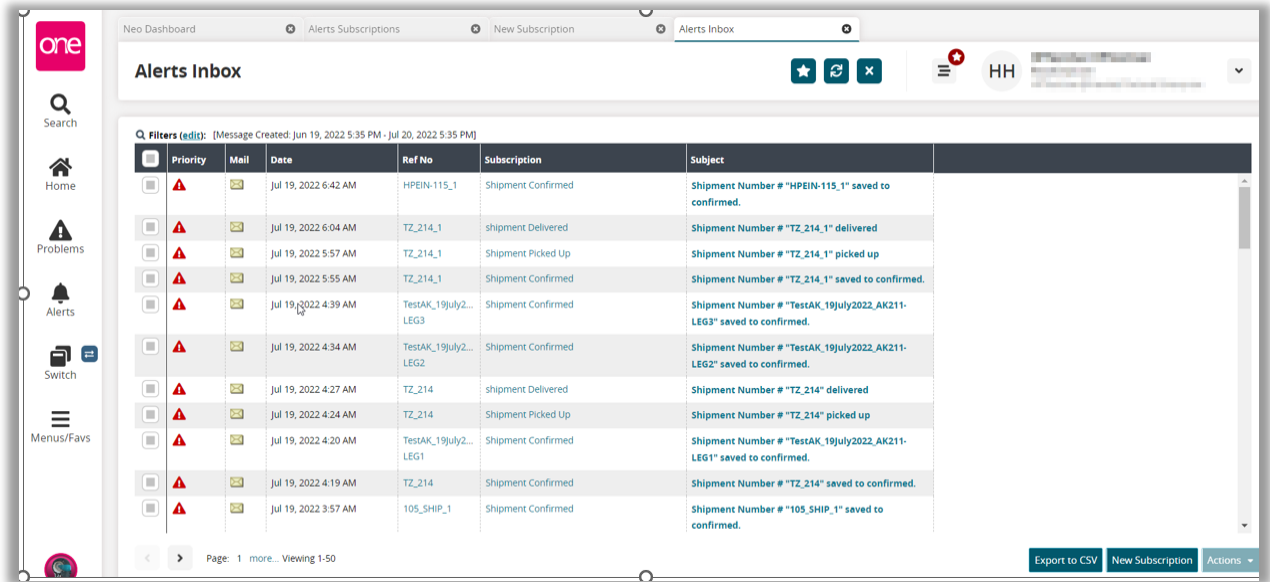

3. On the **Alerts Inbox** screen, you can mark an alert as “read” by selecting the envelope symbol for the alert. The envelope symbol changes to an open envelope to signify to you that you have already read and acknowledged this alert.

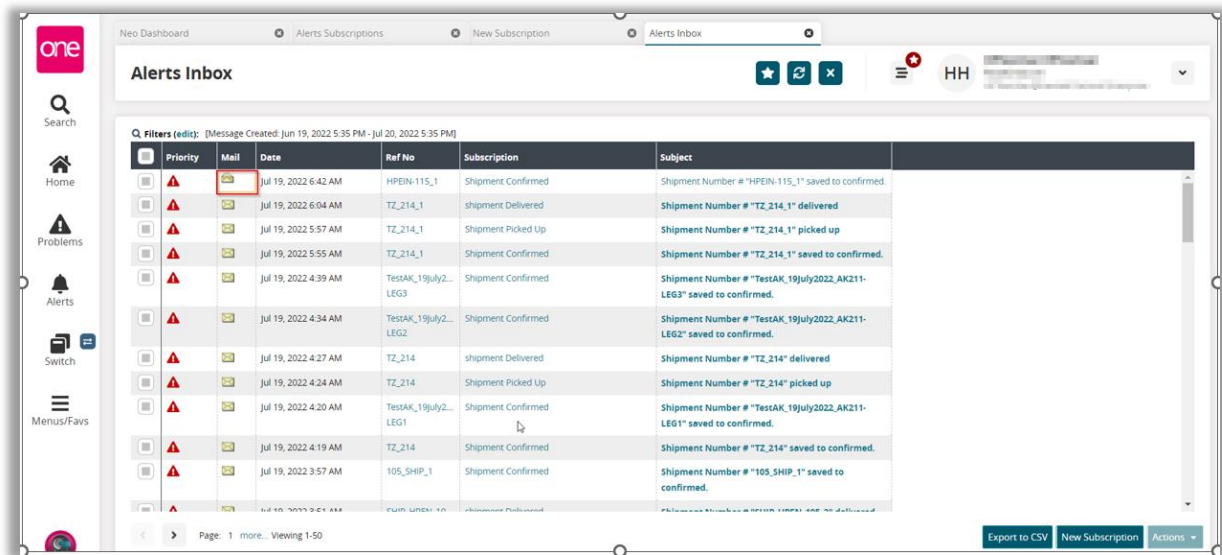

- To delete an alert message, select the checkbox next to the alert message and click the **Actions** button and select **Delete Checked**.

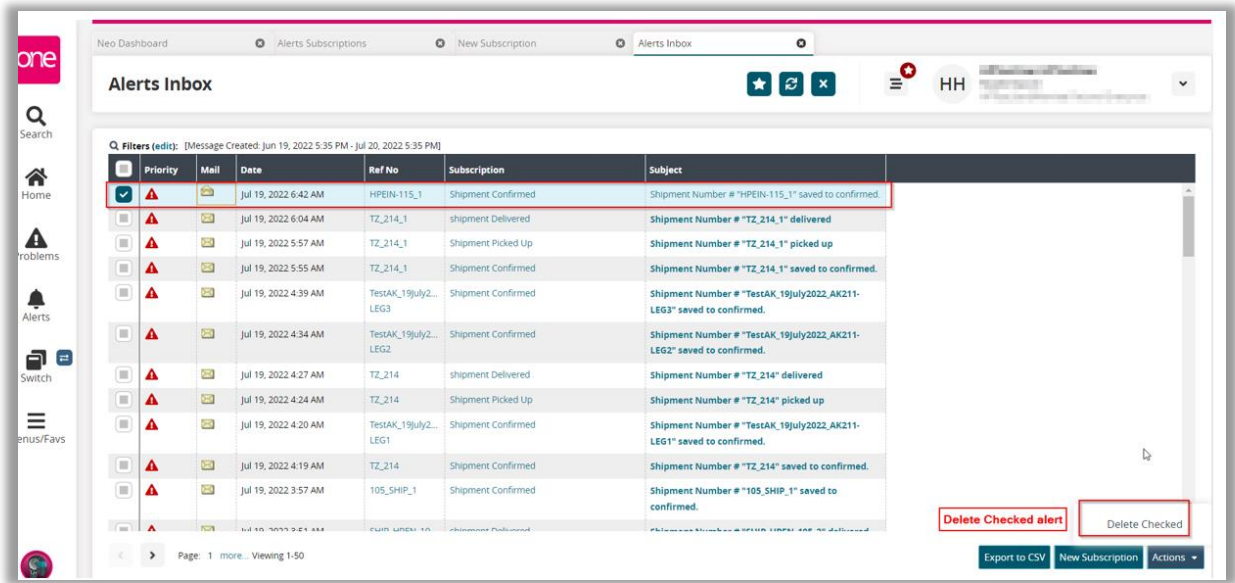

Milestones

Context

Activity Purpose	To add Alerts for various milestones associated with Shipment.
Activity Initiators	
Activity Prerequisites	Custom Milestones must be present
Activity Performer(s)	Carrier User
Other Parties Involved	
Additional Information	
Activity Outcome	Alerts will be added against Milestones.

Process Flow

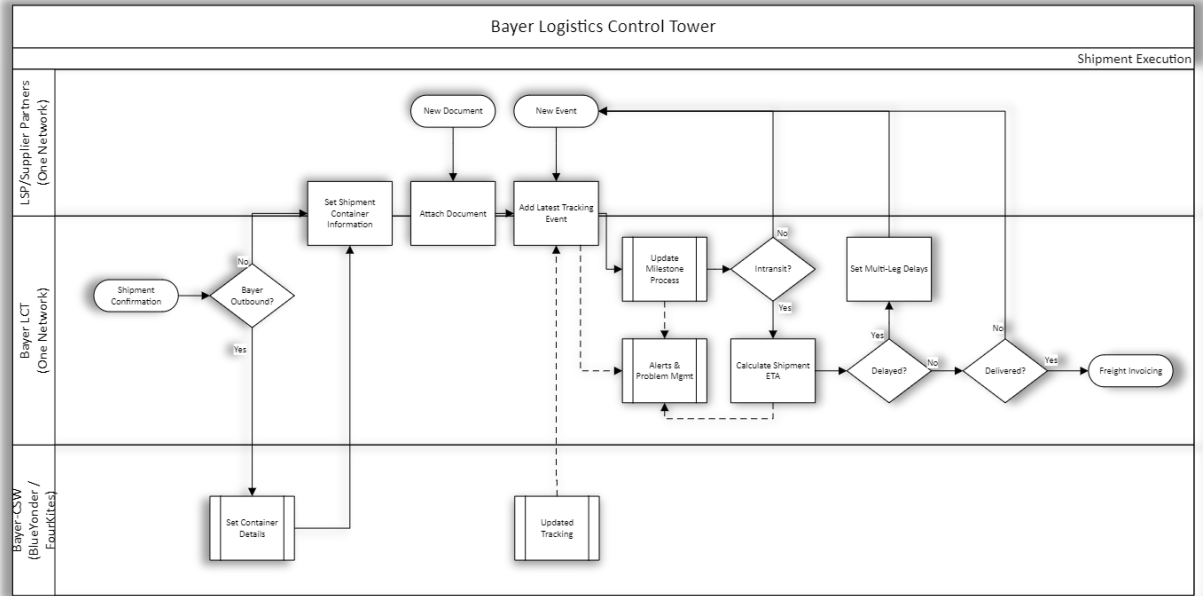

System Steps

Milestones are defined as process steps that will be monitored, are defined, and tracked based on the underlying Shipment or Order events and are customer defined. These milestones will also measure Bayer and business partner performance in performing these functions and allow Bayer to undertake detailed root cause analysis of challenges and bottlenecks in their logistics supply chain.

Searching Shipment Milestones from Shipment

Shipment Milestones support defining configurable milestones linked to tracking events on a shipment.

Informational Events

These are the standard shipment tracking events that are key events to meet customer defined Milestones, that can track operational performance at detailed requirements. Includes events such as Arrived at Site, Departed Site, Delayed, Arrived at Dock, etc.

1. Log into the application as a Transportation user.
2. Click Menus/Favs and navigate to Transportation > Search Shipment by State

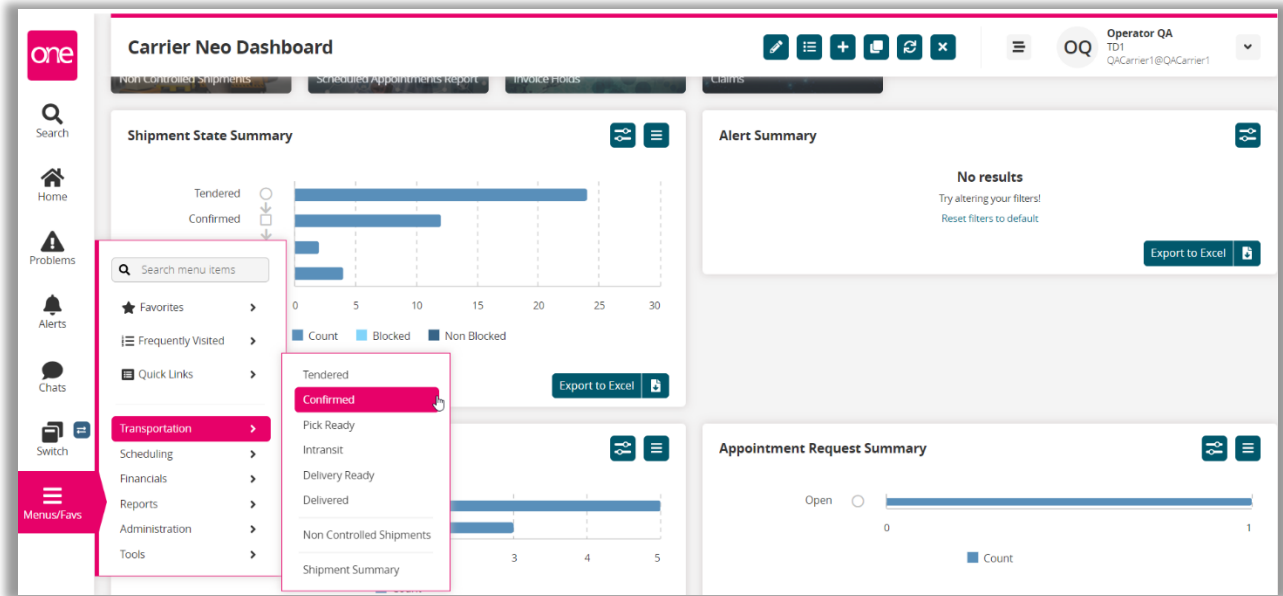

The Shipment report appears of all confirmed shipments.

The 'Confirmed' report displays a table of shipment details. The table includes columns for Movement, Shipment, Flags, Cost, Shipper, Consignee, Pickup, Delivery, Target Pickup/Actual Pickup, and Target Delivery/Actual Delivery.

Movement	Shipment	Flags	Cost	Shipper	Consignee	Pickup	Delivery	Target Pickup/Actual Pickup	Target Delivery/Actual Delivery
M-Testing_PDS-74975-1	Testing_PDS-74975-1		100.00 USD	DC1 Dallas, TX 75001	DC2 Fortworth, TX 76199	Apr 10, 2024 6:00 AM - 8:00 AM [215131 Live]	Apr 24, 2024 3:54 AM - 3:54 AM Create [Live]	Apr 15, 2024 3:53 AM	Apr 24, 2024 3:54 AM
M-1542401-2	1542401-2		100.00 USD	DC1 Dallas, TX 75001	DC2 Fortworth, TX 76199	Apr 15, 2024 7:00 AM - 9:00 AM [215134 Live]	Apr 24, 2024 3:54 AM - 3:54 AM Create [Live]	Apr 15, 2024 3:53 AM	Apr 24, 2024 3:54 AM
M-1542401-5	1542401-5		100.00 USD	DC1 Dallas, TX 75001	DC2 Fortworth, TX 76199	Apr 15, 2024 11:00 AM - 1:00 PM [215136 Live]	Apr 24, 2024 3:54 AM - 3:54 AM Create [Live]	Apr 15, 2024 3:53 AM	Apr 24, 2024 3:54 AM
M-1542401-4	1542401-4		100.00 USD	DC1 Dallas, TX 75001	DC2 Fortworth, TX 76199	Apr 15, 2024 5:00 AM - 7:00 AM [215133 Live]	Apr 24, 2024 3:54 AM - 3:54 AM Create [Live]	Apr 15, 2024 3:53 AM	Apr 24, 2024 3:54 AM
M-1542401-1	1542401-1		100.00 USD	DC1 Dallas, TX 75001	DC2 Fortworth, TX 76199	Apr 15, 2024 3:00 AM - 5:00 AM [215132 Live]	Apr 24, 2024 3:54 AM - 3:54 AM Create [Live]	Apr 15, 2024 3:53 AM	Apr 24, 2024 3:54 AM

3. Click on Shipment, Shipment details screen appears.

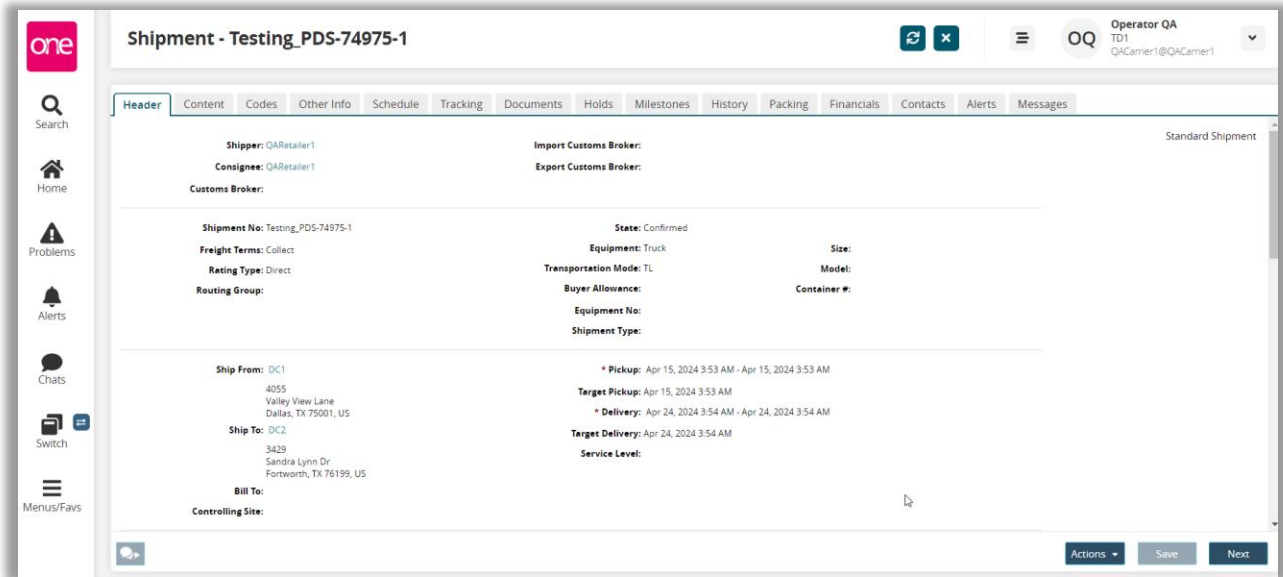

4. Click on **Milestones** Tab, the custom Milestones set up for this Shipment appears.

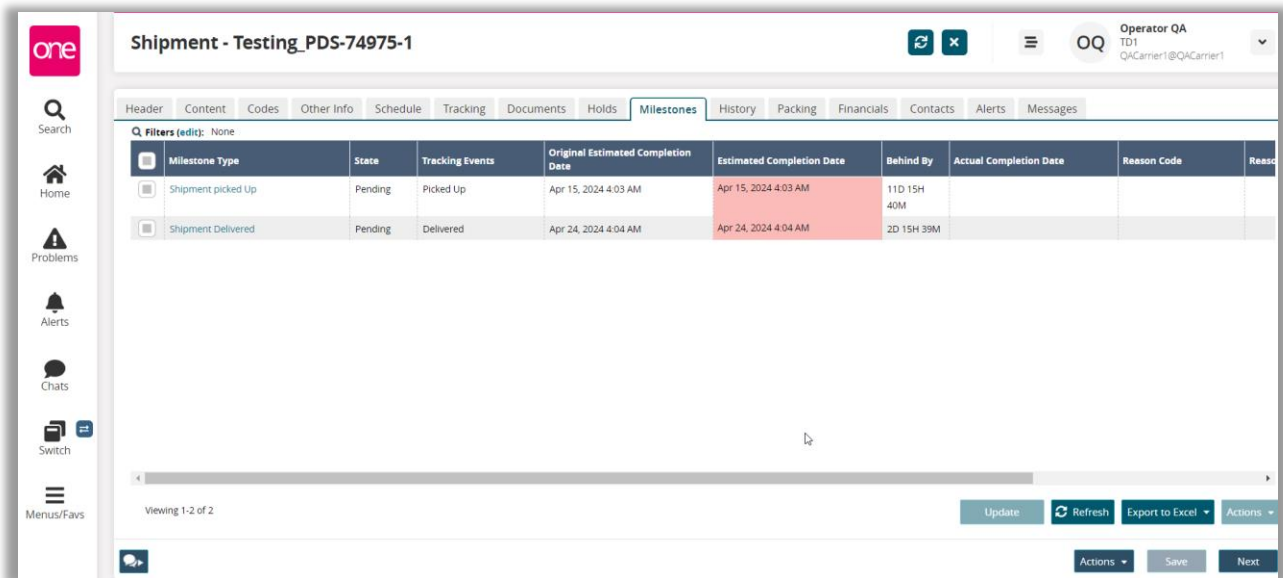

Adding Alerts based on Shipment Milestones Completion / Failure

This section shows how to work with existing milestone processes.

1. Log into the application as a Transportation Manager

- Click Menus/Favs and navigate to Transportation > Search Shipments > Shipment Details screen -> Milestone Tab
The Milestone screen appears. The pink color shows that Milestone completion is running behind.

Shipment - Testing_PDS-74975-1

Operator QA
TD1
QACarrier1@QACarrier1

Header Content Codes Other Info Schedule Tracking Documents Holds Milestones History Packing Financials Contacts Alerts Messages

Filters (edit): None

Milestone Type	State	Tracking Events	Original Estimated Completion Date	Estimated Completion Date	Behind By	Actual Completion Date	Reason Code	Reason
Shipment picked Up	Pending	Picked Up	Apr 15, 2024 4:03 AM	Apr 15, 2024 4:03 AM	11D 15H 40M			
Shipment Delivered	Pending	Delivered	Apr 24, 2024 4:04 AM	Apr 24, 2024 4:04 AM	2D 15H 39M			

Viewing 1-2 of 2

Update Refresh Export to Excel Actions

Actions Save Next

- A Supplier User can either add a tracking event or set up an alert on Pass / Fail / Miss Milestones which can help supplier to track their performance and meet defined SLA for Bayer.
- Please refer sec [Creating New Alerts](#) in this document.